



TECHNICAL MANUAL

Digital timer TE-80 EKF

1 DESCRIPTION

Digital timers TE-80 EKF are designed for automating the control of electrical devices based on preset scenarios by turning appliances on/off at specific times.

Timers TE-80 comply with IEC 60730-2-7.

2 TECHNICAL DATA

The main technical data are listed in Table 1.

Table 1

Characteristics	Values		
	TE-80	TE-80 24-230 V	TE-80-2 24- 230 V
Rated supply voltage U_n , V	AC 220- 240	AC/DC 24-264	
Rated frequency, Hz	50 / 60		
Maximum switching current (AC-1), A	16		
Type and number of contacts	1 CO		2 CO
Insulation voltage U_i , V	300		
Number of channels	1		2
Power consumption, W	1		2
Program type	Weekly, pulse		
Operating mode	Manual, auto		
Switching to winter/summer time	Off/auto		
Max. number of scenarios	80		
Clock accuracy per day at 20°C, s	1		
Electrical life, cycles	100 000		

Table 1 continued

Characteristics	Values		
	TE-80	TE-80 24-230 V	TE-80-2 24- 230 V
Mechanical life, cycles	1 000 000		
Operating temperature, °C	from -20 to 55		
Max. air humidity at 40°C, %	50		
Storage temperature °C	from -30 to 70		
Degree of protection	IP20		
Min. battery life, years	3	10	
Maximum cross-section of connected wires, mm ²	4		
Tightening torque, N·m	0,5		

Table 2 - Power consumption vs consumer type

Type of consumers	Power, W
Incandescent lamps, halogen lamps, electric heaters	2300
Fluorescent lamps	1000
Fluorescent compensated lamps	500
ESL, ESG lamps	500

The product must be operated under the following environmental conditions:

- Non-explosive environment;
- No corrosive gases and vapors in concentrations damaging to metals and insulation;
- No saturation with current-conducting dust and vapors;
- No direct exposure to ultraviolet radiation;

The product housing is made of flame retardant ABS plastic.

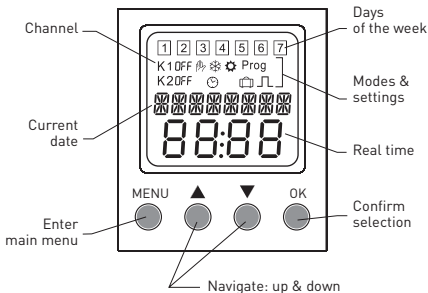









Figure 1. Device front panel

For the symbols displayed on the screen refer to Table 3.

Table 3

	Relay status (OFF/ON)
	Manual control
	Automatic control (scenario)
	Switching to winter time
	Switching to summer time
Prog	Program settings
	Holiday mode
	Pulse mode

The timer has a protective transparent cover with sealing option. A built-in lithium battery ensures that the timer will keep its settings for 3 years in the event of power failure.

Integrated microprocessor enables execution of 80 preprogrammed control scenarios.

If necessary, the timer can be put to the holiday mode, suspending the execution of the configured scenario. The timer also has a manual mode in which the output state of the contacts is controlled directly by the user.

3 INSTALLATION AND OPERATION

The device is installed in the distribution enclosure onto a 35 mm DIN rail.

To avoid interference, false tripping, or malfunctioning of the relay, do not route the relay power supply wires along the power circuit wiring. If necessary, use a shielded cable.

Screw terminals support copper and aluminium wires with max. cross-section of 4 mm². Before connecting stranded conductors, terminate them with a ferrule or a sleeve using an appropriate tool.

Built-in lithium battery will fully charge within 24 hours from powering the timer.

3.1 SETUP AND PROGRAMMING

Initial settings:

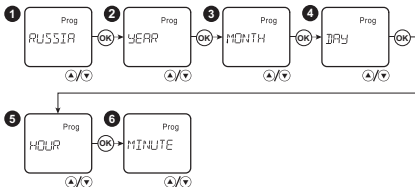

When the timer is turned on for the first time (or after a reset), use the ▼▲ and OK buttons to set the language, date and time.

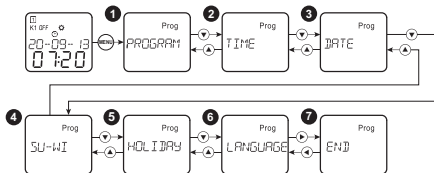

Press and hold the MENU button for 2 seconds to enter the menu.

Main Menu:

Table 4

1	PROGRAM	Programming mode
2	TIME	Setting up the time
3	DATE	Setting up the date
4	DST	Setting up the daylight saving time
5	HOLIDAY	Setting up the holiday mode
6	LANG	Setting up the language
7	END	End settings process and exit from the menu

Press the MENU button to enter the main menu.

Use the ▼▲ buttons to choose the menu item. The timer will automatically exit the menu after two minutes of inactivity.

Setting up the clock:

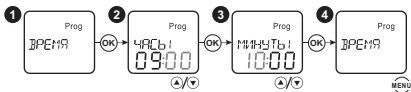

Select the menu item TIME, and press the OK button. Use the ▼▲ buttons to set up the hour and minute, and press the OK button to confirm. By pressing and holding the ▼▲ buttons you can change the values quicker. Press MENU to exit from the settings.

Setting up the date:

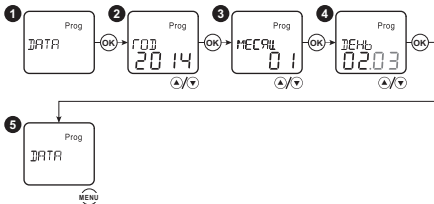

Select the DATE menu item, and press the OK button. Use the ▼▲ buttons to set up the year, month, and day, and press OK to confirm. By pressing and holding the ▼▲ buttons you can change the values quicker. Press MENU to exit from the settings.

Setting up the daylight saving time:

Select the DST menu item, and press the OK button. Select the appropriate DST using Table 5 for reference.

Press MENU to exit from the settings.

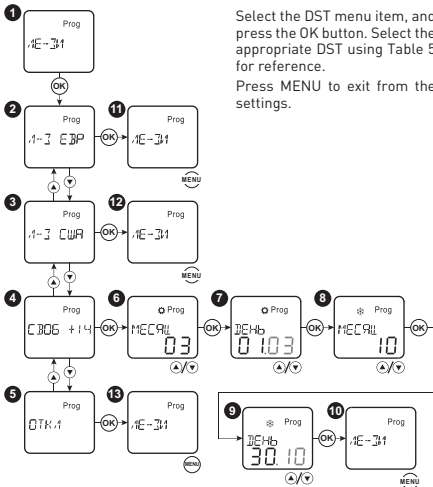
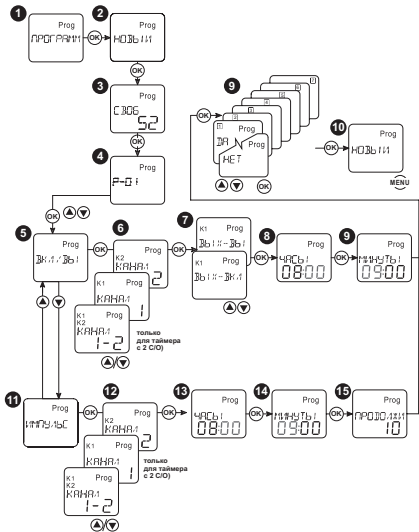

Table 5

Display	Function	Spring forward	Fall back
DST EUR	European countries	Last Sunday of March	Last Sunday of October
DST USA	USA	Second Sunday of March	First Sunday of November
FREE+14	Programming	Programmable	Programmable
OFF	Disabled	N/A	N/A

Setting up a new scenario:

Select the PROGRAM menu item, and press the OK button. Select NEW menu item, and press the OK button. After this, the display will show the free memory spaces. If the memory of the timer is full, a new program will not be created and the display will show the FULL message. Select the scenario number, and press the OK button to confirm. Select ON/OFF mode and then PULSE mode. Select the position of the output contacts. Press the OK button to confirm. Set the pulse duration within 1-99 sec. range. Set the scenario for a week from Monday to Sunday (item 9 in the diagram). If an extra step is required, press the OK button and repeat the setting steps. Press the MENU button to finish the setting process.



Changing the existing scenario:

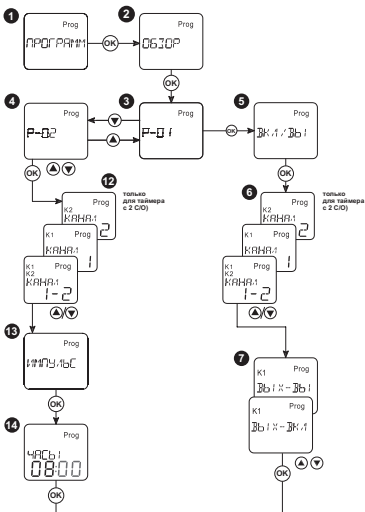

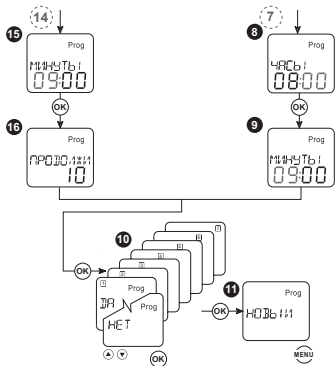

Select the PROGRAM menu item, and press the OK button. Select the VIEW menu item, select the program and press the OK button, repeat the actions described in the "Setting up a new scenario" section.

Deleting a scenario:

Select the PROGRAM menu item, and press the OK button. Select the DELETE menu item, and press the OK button. If you want to delete a single scenario, select the ONE menu item, navigate to the required scenario number with the \blacktriangledown / \blacktriangle buttons and press the OK button. If you want to delete all existing scenarios, select the ALL menu item, and press the OK button to clear the memory.

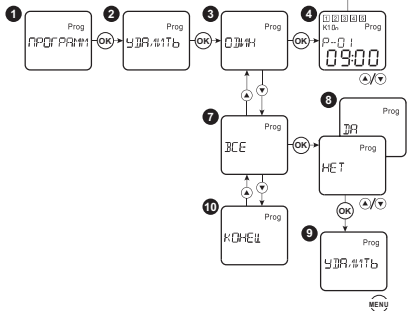

Viewing the existing scenarios:

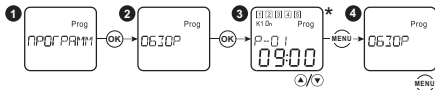

* P-01 09:00	ВКЛ/ВЫКЛ ПРОГРАММЫ
P-02 09:00	ИМПУЛЬС ПРОГРАММЫ

Select the PROGRAM menu item, and press the OK button. Select the VIEW menu item, and press the OK button. Use the ▼▲ buttons to browse the previously configured scenarios.

Setting up the holiday mode

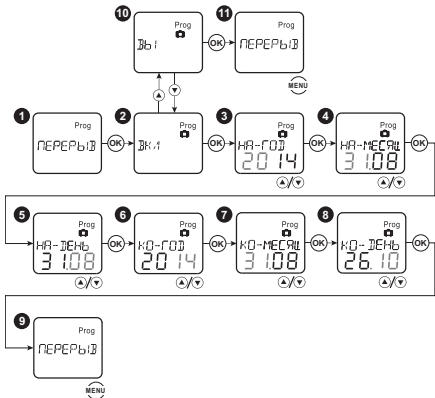

Select the PROGRAM menu item, and press the OK button. Select the HOLIDAY menu item, and press the OK button. Set the year, month and day of activating and deactivating the holiday mode. To deactivate the HOLIDAY mode, select the OFF menu item and press the OK button.

Language selection:

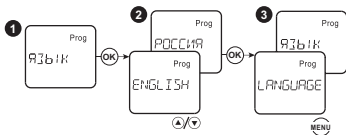

Manual load control:



AUTO/MANUAL

Press the ▼▲ buttons to switch to manual control of K1 channel load. When the scenario settings of the K1 channel are changed, the timer reverts to automatic mode.



Press the ▼ and OK buttons at the same time to switch to manual control of the K2 channel load. When the scenario settings of the K2 channel are changed, the timer reverts to automatic mode.



ALWAYS-ON/ALWAYS-OFF

Press and hold the ▼▲ buttons at the same time for 2 seconds to switch to ALWAYS-ON/ALWAYS-OFF manual control



Press and hold the ▼ and OK buttons at the same time for 2 seconds to switch to ALWAYS-ON/ALWAYS-OFF manual control

Factory reset:

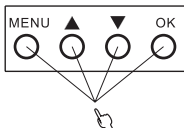

Press and hold the MENU, ▼▲ and OK buttons for 4 seconds to reset the timer to factory settings.

4 WIRING DIAGRAMS

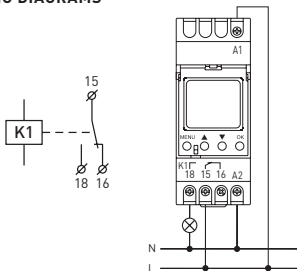

Figure 2

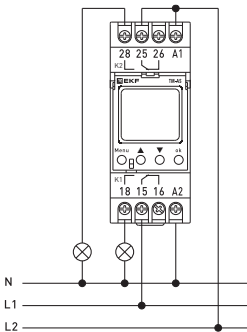
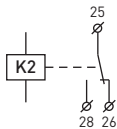
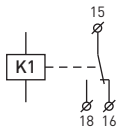

Figure 3

5 OVERALL AND INSTALLATION DIMENSIONS

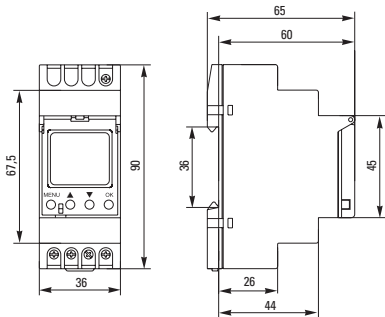

Figure 4. Overall and installation dimensions

6 DELIVERY SCOPE

The timers are supplied in a group package. For all available documentation, scan the QR-code on the insert or on the inside of the package.

7 SAFETY REQUIREMENTS

WARNING! Hazardous voltage

The device conforms to IEC 61140 Class 0 for protection against electrical shock.

The devices shall be installed and serviced by qualified electrical personnel only.

Do not operate any timers with visible mechanical damage.

For maintenance of timers, follow national safety rules for operation of electrical Installations.

Do not operate timers with damaged housing.

Failure to comply with the instructions may lead to product malfunction, electrical shock or fire.

The timer does not require any specific maintenance. Tighten the screw terminals of the timer every 6 months.

8 TRANSPORTATION AND STORAGE

Timers can be transported by any means of enclosed transport that protects the packaged goods from mechanical impact and weather exposure.

Thermostats shall be stored in the original package indoors at the ambient temperature from -40° C to 70° C and relative humidity of max. 90% at +25°C.

9 DISPOSAL

Life-expired and failed timers shall be disposed of in compliance with the effective national and local laws and regulations. To dispose of the product, send it to an authorized company for recycling in compliance with the effective national and local laws and regulations.

10 MANUFACTURER'S WARRANTY

The manufacturer guarantees the timers comply with the declared characteristics, provided that the consumer follows the operation, transportation and storage conditions.

Warranty period: 7 years from the date of sale specified in the sales receipt.

Shelf life: 7 years from the date of manufacture specified on the product packaging or housing.

Service life: 10 years.

Manufacturer: 000 Electroresheniya, Otradnaya st.,
2b/9, 127273, Moscow, Russia, tel. +7 (495) 788-88-15.

MEA regional headquarters: EKF ELECTRICAL SOLUTION
FZCO, Techno Hub-2, DSO, P.O. box 341079, Dubai, United
Arab Emirates, tel. +971-4-547-06-18.

**Importer and EKF trademark service representative
in the territory of the Republic of Kazakhstan:**

TOO «Energoresheniya Kazakhstan», Kazakhstan,
Almaty, Bostandyk district, Turgut Ozal st., 247, apt 4.

11 CERTIFICATE OF ACCEPTANCE

Timers TE-80 EKF have been manufactured in compliance with
laws and regulations in force and have been approved for operation.

Date of manufacture: for information,
refer to the product housing or package.

Quality control stamp



EAC



v3

ekfgroup.com

EEVEE